



LATERAL MECHANICAL CONTROLS WITH TRACTION ACTING WITH LOCKING (medium loads applications - single cable) AND ORDER FORM MODEL SM 200B

Characteristics:

Cable linear stroke in locking position at stroke end: 25 - 34 - 42 - 50 mm (in intermediate locking 15 - 20 - 25 - 30 mm)

Assembly: on walls or on tubes

Fastening type: on walls with two fastening screws or on tubes with a through screw

Tube outer diameter: 22 mm - 25 mm - 26 mm - 27 mm - 28 mm - 30 mm

Lever functioning: free with intermediate safety block and locking at stroke end.

Holder material: metal Lever and external carter material: nylon

Colour: black

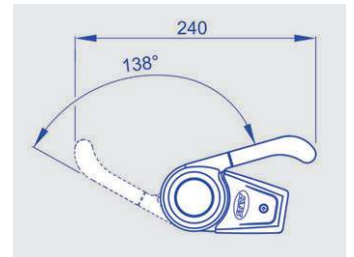
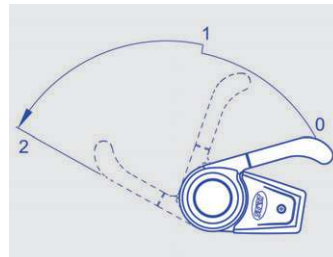
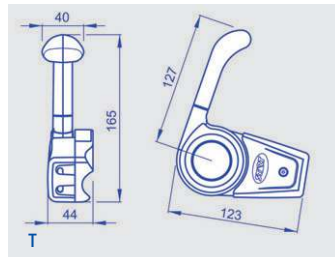
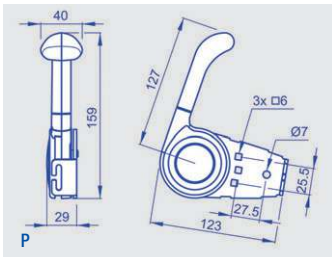
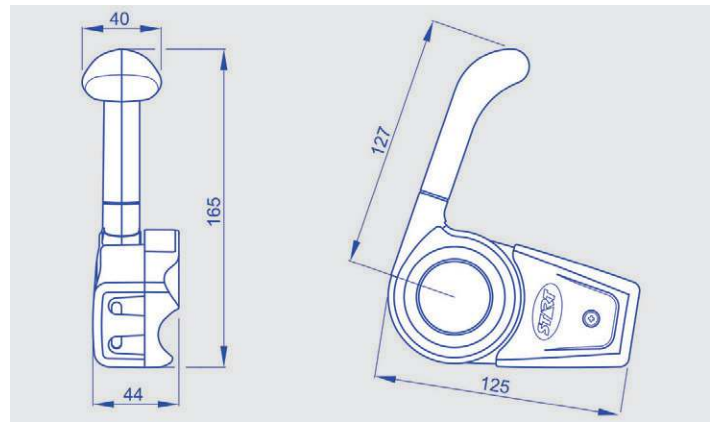

To order: compose, please, your product code inserting the boldfaced code corresponding to the chosen option in the proper square.

SM 200B

- Linear stroke with locking at stroke end mm 25: **01**
- Linear stroke with locking at stroke end mm 34: **02**
- Linear stroke with locking at stroke end mm 42: **03**
- Linear stroke with locking at stroke end mm 50: **04**

- Wall assembly (P): **05**
- Assembly on outer tube (T) Ø mm 22: **06**
- Assembly on outer tube (T) Ø mm 25: **07**
- Assembly on outer tube (T) Ø mm 26: **08**
- Assembly on outer tube (T) Ø mm 27: **09**
- Assembly on outer tube (T) Ø mm 28: **10**
- Assembly on outer tube (T) Ø mm 30: **11**

Intermediate safety block: it prevents the accidental passage of the lever from the resting position to the final locking position and vice versa. The lever must be operated voluntarily, through two distinct movements: the operation, therefore, must be wanted.



LATERAL MECHANICAL CONTROLS COMPATIBLE CABLES MODELS SM 200B - SM 200T

Characteristics:

Sheath diameter: Ø6 mm or Ø7 mm with inner antifriction tube

Sheath length: upon request

Wire diameter: Ø1,9 mm or Ø2,5 mm

Wire protrusion length: upon request

Sheath terminals: see table

Wire terminals: see table

Sheath options

Wire options

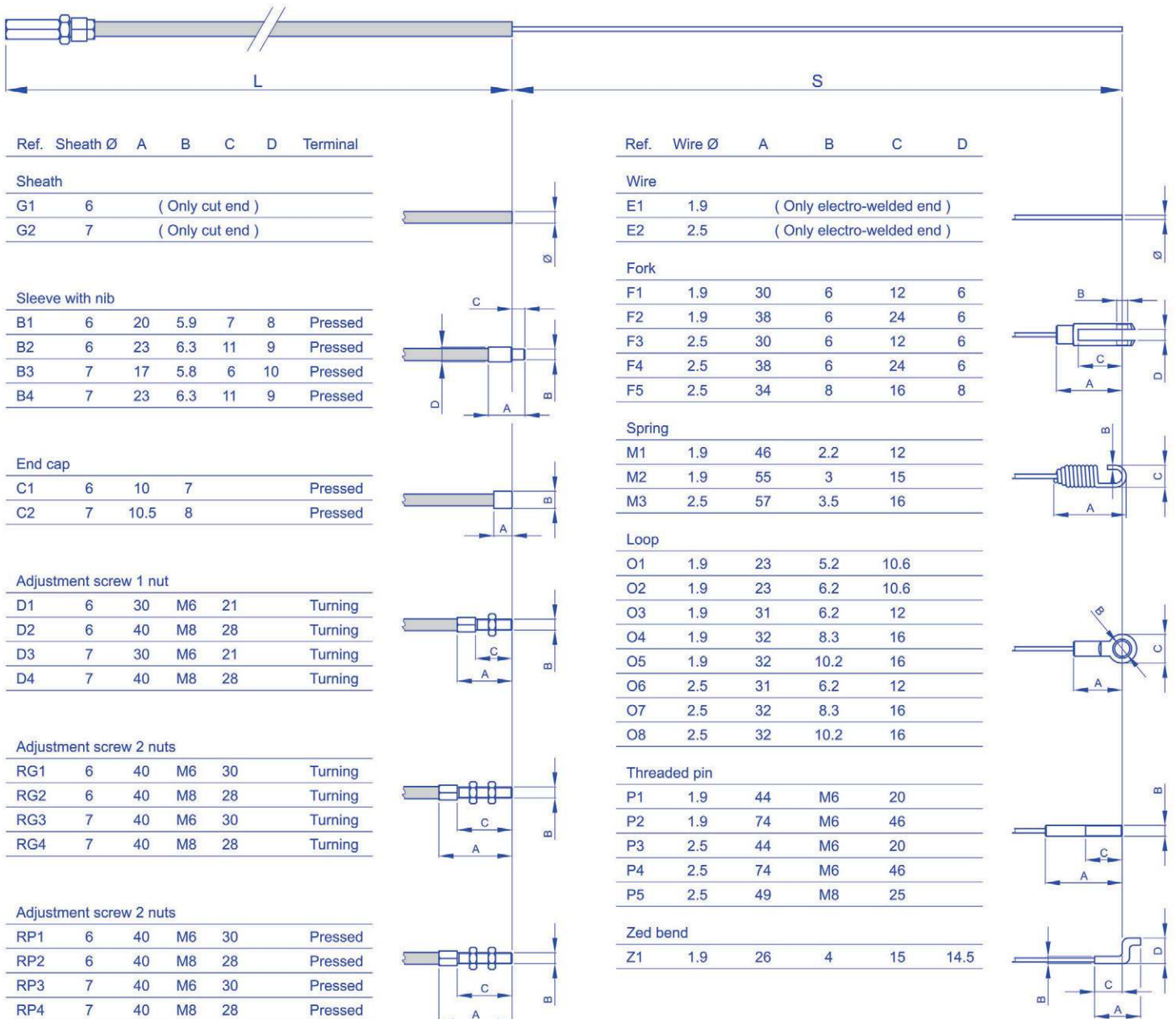



LATERAL MECHANICAL CONTROLS ORDER FORM FOR COMPATIBLE CABLES MODELS SM 200B - SM 200T

To order:

The technical options that are represented on the opposite page are the standard personalizations which are provided from the company.

Among these possibilities, you can choose the cable construction that meets your requirements.

At first choose the sheath diameter and select the corresponding terminals among the possible options.

Find out your preferences and fill in the boxes with the number or the letters/number corresponding to your options.

Example: if you choose a Ø7 mm sheath and you want a sleeve with nib as terminal, indicate the code 02 or 03, according to your needs.

And so on for other variables.

The same procedure must be used to choose the wire: start choosing the diameter and then select the corresponding options.

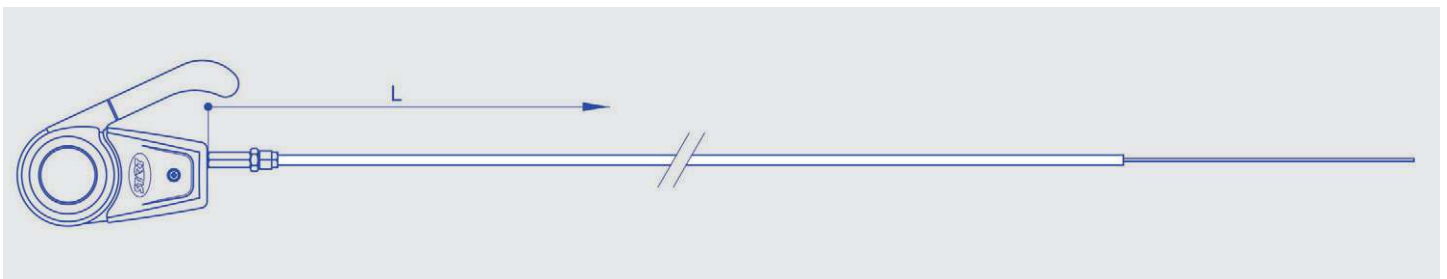

To order: compose, please, your product code inserting the boldfaced code corresponding to the chosen option in the proper square.

Cable							
-------	--	--	--	--	--	--	--

Sheath length (L) in mm: _____

Wire protrusion length (S) in mm: _____

Sheath Ø6 mm (only cut) G1: **01**

Sheath Ø7 mm (only cut) G2: **02**

Sleeve with nib B1: **03**

Sleeve with nib B2: **04**

Sleeve with nib B3: **05**

Sleeve with nib B4: **06**

End cap C1: **07**

End cap C2: **08**

Adjustment screw 1 nut D1: **09**

Adjustment screw 1 nut D2: **10**

Adjustment screw 1 nut D3: **11**

Adjustment screw 1 nut D4: **12**

Turning adjustment screw 2 nuts RG1: **13**

Turning adjustment screw 2 nuts RG2: **14**

Turning adjustment screw 2 nuts RG3: **15**

Turning adjustment screw 2 nuts RG4: **16**

Pressed adjustment screw 2 nuts RP1: **17**

Pressed adjustment screw 2 nuts RP2: **18**

Pressed adjustment screw 2 nuts RP3: **19**

Pressed adjustment screw 2 nuts RP4: **20**

Only electro-welded wire Ø1,9 mm without terminal E1: **21**

Only electro-welded wire Ø2,5 mm without terminal E2: **22**

Fork F1: **23**

Fork F2: **24**

Fork F3: **25**

Fork F4: **26**

Fork F5: **27**

Spring M1: **28**

Spring M2: **29**

Spring M3: **30**

Loop O1: **31**

Loop O2: **32**

Loop O3: **33**

Loop O4: **34**

Loop O5: **35**

Loop O6: **36**

Loop O7: **37**

Loop O8: **38**

Threaded pin P1: **39**

Threaded pin P2: **40**

Threaded pin P3: **41**

Threaded pin P4: **42**

Threaded pin P5: **43**

Zed bend Z1: **44**