

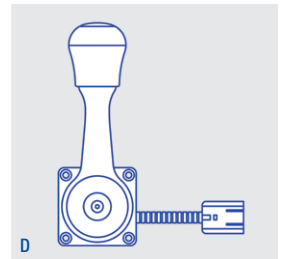

## LATERAL ELECTRONIC CONTROLS MECHANICAL COMPONENT WITH ACCELERATOR FUNCTION AND ORDER FORM MODEL LM 100

**Characteristics:**

- Assembly: on walls Fastening type: with M5 screws
- Lever functioning: frictioned having an adjustable stiffness
- Functioning from P0 to P1: clockwise or counter clockwise (P0 corresponds to the beginning of the sensor scale)
- Lever material: stainless steel Lever typology: straight or bent
- Lever rotation arch: 60°
- Holder material and colour: black reinforced resin Knob material and colour: black or red nylon
- Electric wires exit: on the left or on the right

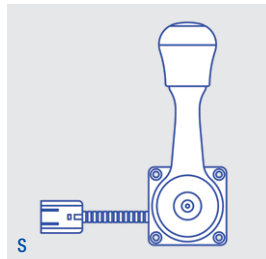
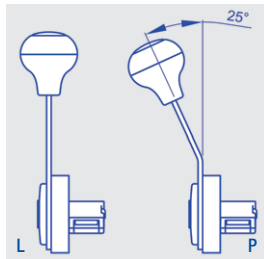
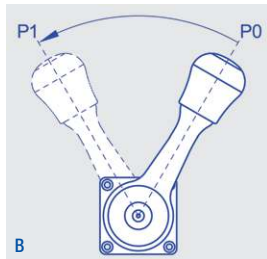
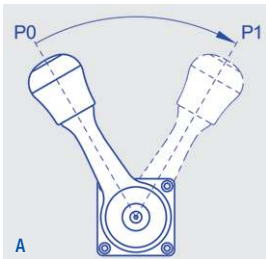
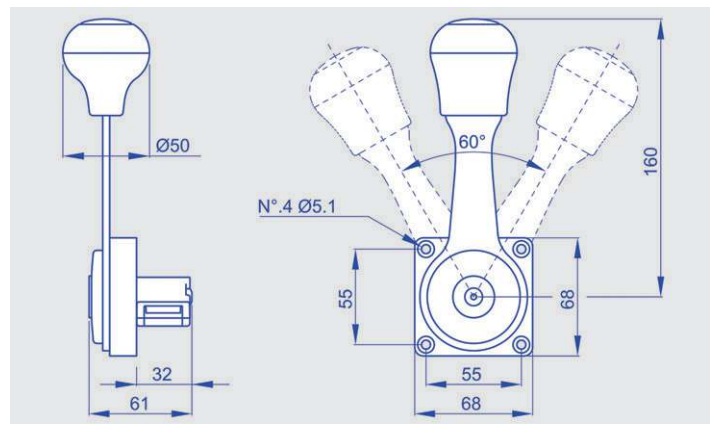

To order: compose, please, your product code inserting the boldfaced code corresponding to the chosen option in the proper square.

LM 100

Functioning "P0 - P1" clockwise: **A**  
Functioning "P0 - P1" counter clockwise: **B**

Straight lever: **L**  
Bent lever: **P**

Black knob: **N**  
Red knob: **R**

Wire exit on the left: **S**  
Wire exit on the right: **D**



# LATERAL ELECTRONIC CONTROLS PREVALENT SOFTWARE COMPONENT AND ORDER FORM MODEL LM 100

### Main characteristics:

- Angle signal output: analog
- Beginning scale angle signal (IS): 0,2→4,9 Vdc
- Full-scale angle signal (FS): 0,2→4,9 Vdc
- Digital signal polarity (IVS validation): positive or negative

N.B. The below described software are examples extrapolated from a much broader generality.  
The performances can therefore be modified. For specific and different needs Start s.r.l. is at disposal.

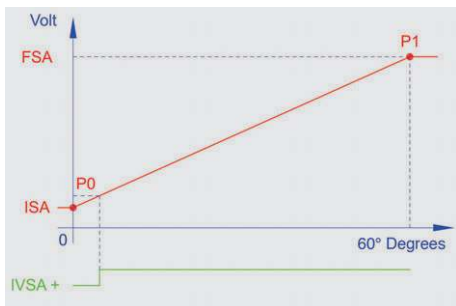

AF1: Analog output, positive IVSA, STL1D sensor

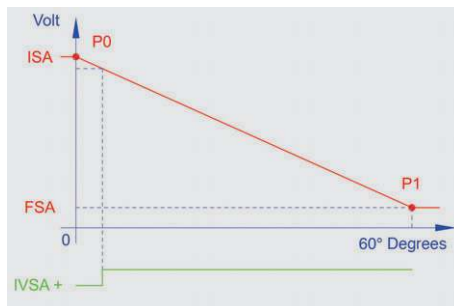

AF2: Analog output, positive IVSA, STL1D sensor

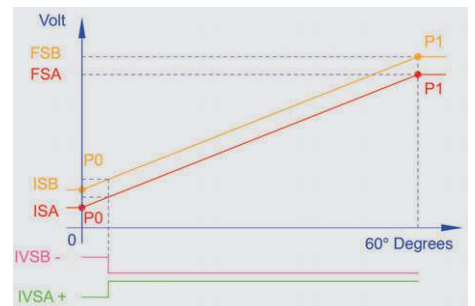

AF3: Two parallel analog outputs, positive IVSA and negative IVSB, STL1 DUAL sensor

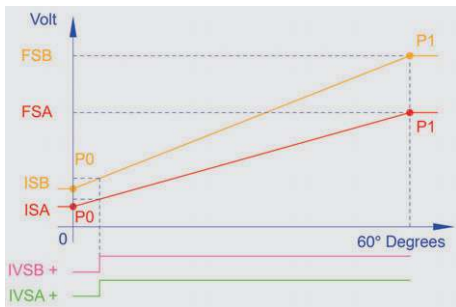

AF4: Two discordant analog outputs, positive IVSA and positive IVSB, STL1 DUAL sensor

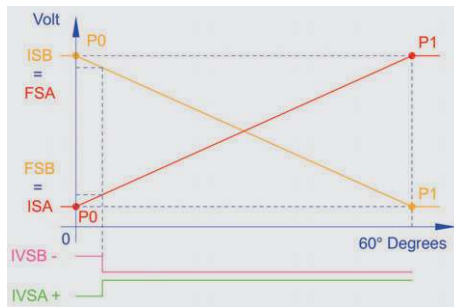

AF5: Two crossed analog outputs, positive IVSA and negative IVSB, with ISA=FSB and FSA=ISB values, STL1 DUAL sensor

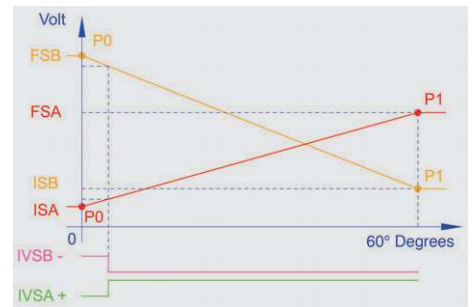

AF6: Two crossed analog outputs, positive IVSA and negative IVSB, STL1 DUAL sensor

**To order: compose, please, your product code inserting the boldfaced code corresponding to the chosen option in the proper square.**

<b>AF</b>									
-----------	--	--	--	--	--	--	--	--	--

- Software AF1: **1**
- Software AF2: **2**
- Software AF3: **3**
- Software AF4: **4**
- Software AF5: **5**
- Software AF6: **6**

ISA beginning scale signal from: **0,2** to **4,9** Vdc

FSA full-scale signal from: **0,2** to **4,9** Vdc

IVSA signal positive polarity: **P**  
IVSA signal negative polarity: **N**

IVSB signal positive polarity (only for AF3, AF4, AF5, AF6): **P**  
IVSB signal negative polarity (only for AF3, AF4, AF5, AF6): **N**

FSB full-scale signal (only for AF3, AF4, AF5, AF6) from: **0,2** to **4,9** Vdc

ISB beginning scale signal (only for AF3, AF4, AF5, AF6) from: **0,2** to **4,9** Vdc



## LATERAL ELECTRONIC CONTROLS HARDWARE COMPONENT AND ORDER FORM MODEL LM 100

**Main characteristics:**

Power input: 5 Vdc or 8→36 Vdc (only STL1D)  
Consumption: 20 mA typ (STL1D) and 40 mA typ (STL1 DUAL)  
Protection: silicone filler or coating  
Connector: Delphi 10 pole or free cables

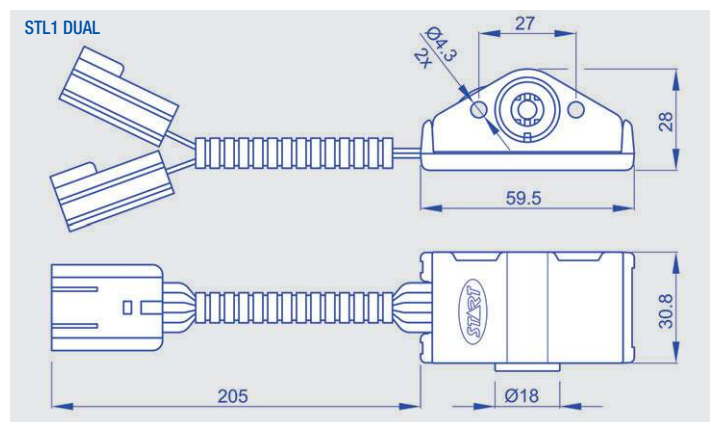
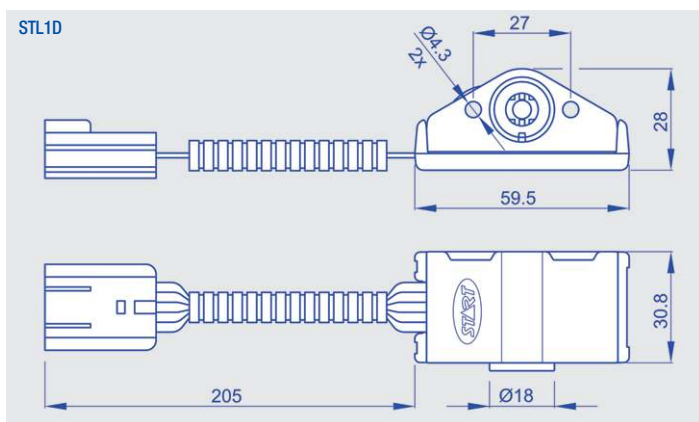

**To order: compose, please, your product code inserting the boldfaced code corresponding to the chosen option in the proper square.**

SENSOR           

Power input 5 Vdc: **5**  
Power input 8→36 Vdc (only STL1D): **8**

Protection with silicone filler: **R**  
Protection with coating: **C**

Connector Delphi 10 pole: **D**  
Free cables: **L**



## LATERAL ELECTRONIC CONTROLS APPLICATIONS EXAMPLES WITH SENSOR STL2D-HP MODEL LM 100

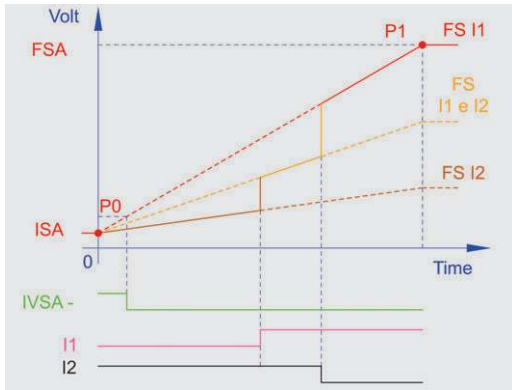

### VARIATION OF THE MAXIMUM SPEED

For reasons of practicality and safety, the maximum achievable speed by a vehicle may need to be changed during the operation. It is the case of the reverse gear, or of difficult manoeuvres. In the beside graphic, some digital input signals of the STL2D-HP are used in this regard, to change the maximum speed of the vehicle.

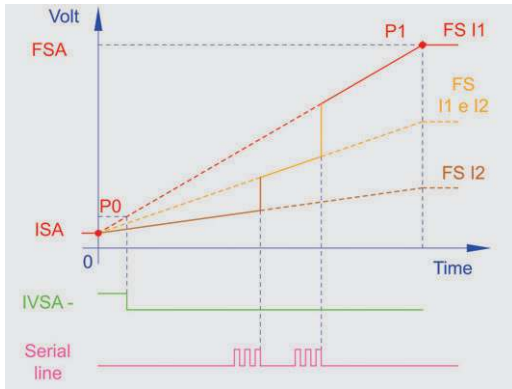

### VARIATION OF THE FULL-SCALE VALUE

As described above, the maximum achievable speed by a vehicle may need to be changed, for example in case of reverse gear or of difficult manoeuvres. In the beside graphic the STL2D-HP available serial line is used to receive a command of full-scale (FS) change.

NOTE: The serial line, used here for a rather simple function, has a much more general and flexible use than the digital signals and can turn the accelerator into a device rich in functionality, which can satisfy the customer's different exigences.

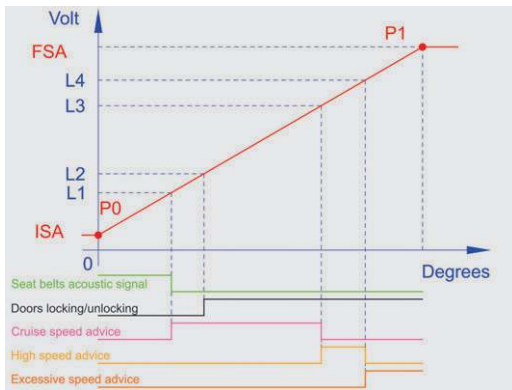

### ACTIVATIONS OF SIGNALS RELATED TO THE SPEED

In the beside graphic an example of an accelerator is represented which is equipped with accessory signals that are activated on the basis of the vehicle speed. The signals are designed to increase the passengers' safety. Corresponding to set speed levels, some signals are activated and, in case of not fastened seat belts, they draw the passengers' attention with an acoustic signal, the doors are locked/unlocked, you are warned if the speed is in the safety range or if it is excessive and similar.

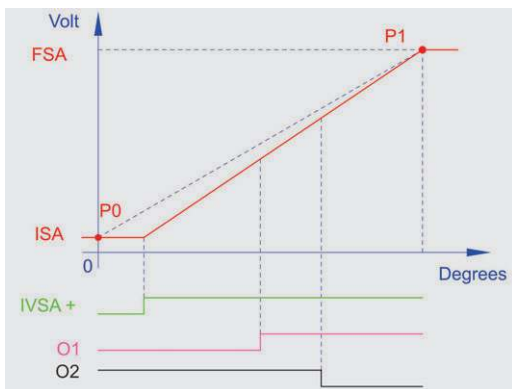

### VARIATION OF THE VALIDATION MANAGEMENT

In the beside graphic a variant of the validation (IVS) management is represented. In this case the output remains at the beginning scale value until the IVS triggers. In this way you eliminate the "jump" in the signal trajectory, which here is visible in the blue sketched trajectory. Of course this different modality DOES NOT involve a faithful proportionality between the output signal and the angular position, but it involves an entity slippage that depends on the IVS value and that is variable during the trajectory, until it vanishes at FS. A system piloted by a sensor, programmed in this way, could evidently ignore the IVS signal, because the output is insensitive to the lever/pedal movement until the IVS planned value is reached, so that this modality can be called "implicit IVS".