



ELECTRONIC DEVICES MECHANICAL COMPONENT WITH FORWARD AND REVERSE GEAR FUNCTION, FRICTIONED WITH CENTRAL ZERO AND ORDER FORM **MODEL CS 120**

Characteristics:

Assembly: on walls

Fastening type: with M5 screws

Device functioning: with friction having an adjustable stiffness and central zero position

Functioning from P0 to P1: clockwise or counterclockwise (P0 corresponds to the beginning of the sensor scale)

Knob and support material and colour: black reinforced resin

Knob rotation arch: 80°

Electric cables outlet: on the left or on the right

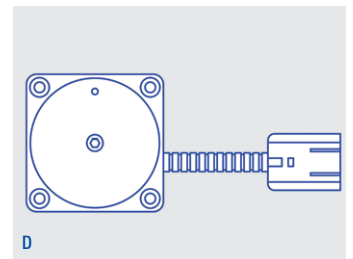
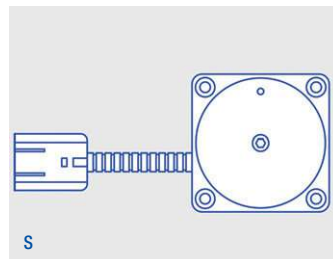
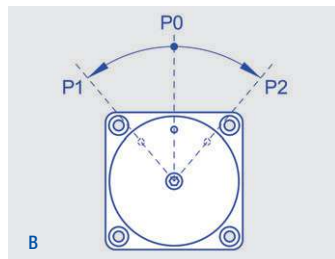
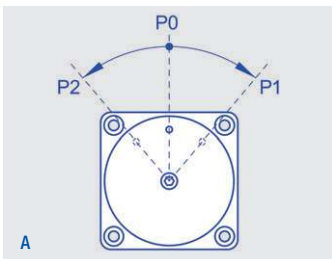
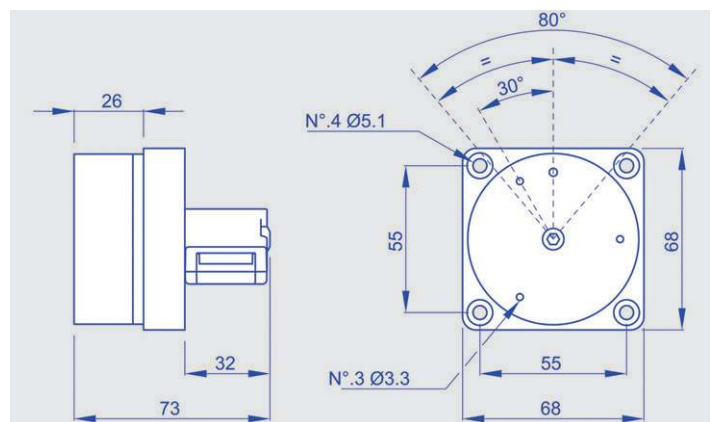

To order: compose, please, your product code inserting the boldfaced code corresponding to the chosen option in the proper square.

CS 120

Functioning "P0 - P1 - P2": **A**

Functioning "P0 - P1 - P2": **B**

Cables outlet on the left: **S**

Cables outlet on the right: **D**



ELECTRONIC DEVICES PREVALENT SOFTWARE COMPONENT AND ORDER FORM MODELS CS 120 - CS 125

Main characteristics:

- Angle signal output: analog
- Beginning scale angle signal (IS): 0,2→4,9 Vdc
- Full-scale angle signal (FS): 0,2→4,9 Vdc
- Digital signal polarity (IVS validation): positive or negative

N.B. The below described software are examples extrapolated from a much broader generality.
The performances can therefore be modified. For specific and different needs Start s.r.l. is at disposal.

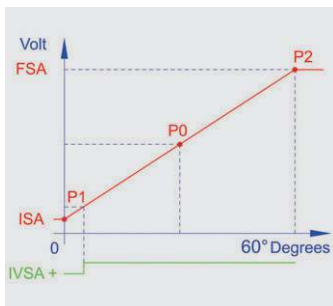

AR1: Analog output, positive IVSA, STL1D sensor

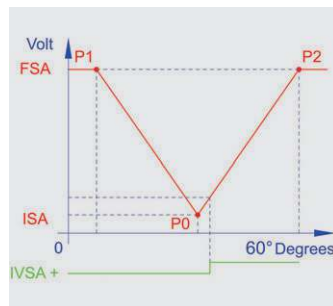

AR2: Symmetrical analog output, positive IVSA, STL1D sensor

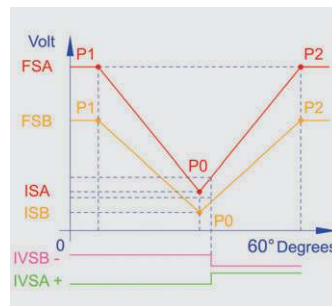

AR3: Two symmetrical analog outputs, positive IVSA and negative IVSB, STL1 DUAL sensor

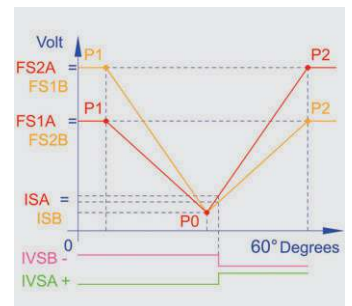

AR4: Two asymmetrical analog outputs, positive IVSA and negative IVSB, STL1 DUAL sensor

To order: compose, please, your product code inserting the boldfaced code corresponding to the chosen option in the proper square.

AR									
-----------	--	--	--	--	--	--	--	--	--

- Software AR1: **1**
- Software AR2: **2**
- Software AR3: **3**
- Software AR4: **4**

ISA beginning scale signal from: **0,2** to **4,9** Vdc

FSA or FS1A full-scale signal (only for AR4) from: **0,2** to **4,9** Vdc

FS2A full-scale signal (only for AR4) from: **0,2** to **4,9** Vdc

- IVSA signal positive polarity: **P**
- IVSA signal negative polarity: **N**

ISB beginning scale signal (only for AR3 and AR4) from: **0,2** to **4,9** Vdc

FSB full-scale signal (only for AR3) or FS1B full-scale signal (only for AR4) from: **0,2** to **4,9** Vdc

FS2B full-scale signal (only for AR4): from **0,2** to **4,9** Vdc

- IVSB signal positive polarity (only for AR3 and AR4): **P**
- IVSB signal negative polarity (only for AR3 and AR4): **N**

The beginning of the sensor scale (ISA – ISB) corresponds to the mechanical zero of the control.



ELECTRONIC DEVICES HARDWARE COMPONENT AND ORDER FORM MODELS CS 120 - CS 125

Main characteristics:

Power input: 5 Vdc or 8→36 Vdc (only STL1D)
Consumption: 20 mA typ (STL1D) and 40 mA typ (STL1 DUAL)
Protection: silicone filler or coating
Connector: Delphi 10 pole or free cables

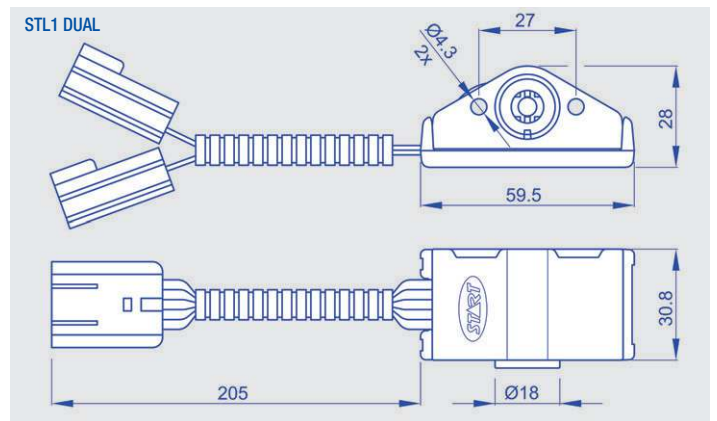
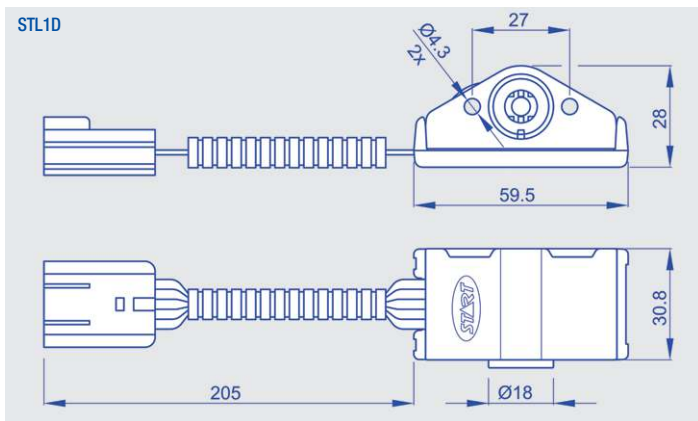

To order: compose, please, your product code inserting the boldfaced code corresponding to the chosen option in the proper square.

SENSOR

Power input 5 Vdc: **5**
Power input 8→36 Vdc (only STL1D): **8**

Protection with silicone filler: **R**
Protection with coating: **C**

Connector Delphi 10 pole: **D**
Free cables: **L**

ELECTRONIC DEVICES APPLICATIONS EXAMPLES WITH SENSOR STL2D-HP MODELS CS 120 - CS 125

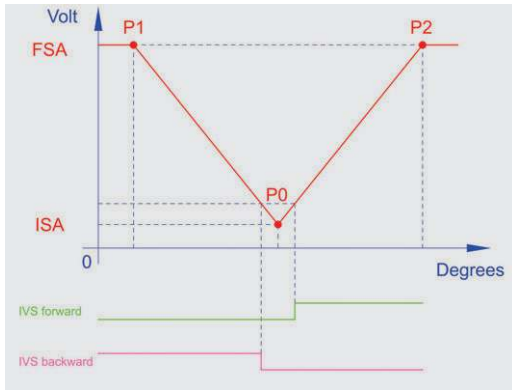

FORWARD / REVERSE GEAR WITH CENTRAL ZERO POSITION AND TWO VALIDATIONS

In the beside graphic a configuration example is represented that is studied to manage, through a lever, the movement forward / backward with central zero position. It is about an application example that is useful on vehicles that need a fast inversion of movement. In this version two validation signals (IVS) are used to distinguish clearly the two movement phases. In central position between the two validations there is a "blind zone" by which the vehicle is stopped. This configuration is optimal under a safety point of view. Using the STL2D-HP sensor, 6 input / output signals are available (I/O), which are definable by the customer (for example actuating acoustic or light signals or devices like valves or engines, corresponding to particular output levels).

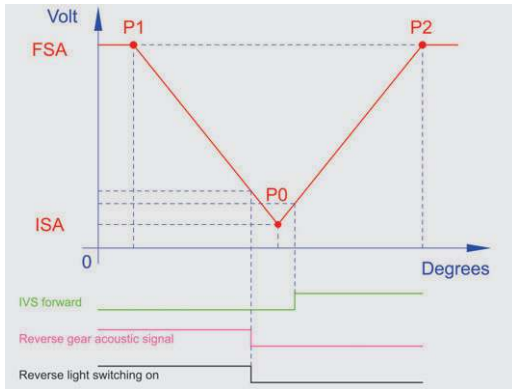

FORWARD / REVERSE GEAR WITH CENTRAL ZERO POSITION AND ONE VALIDATION

In the beside graphic a configuration example is represented that is studied to manage, through a lever, the movement forward / backward with central zero position. It is about an application example that is useful on vehicles that need a fast inversion of movement. In this version a single validation signal (IVS) is used to distinguish the two movement phases. Implicitly, the "low" level of the signal indicates the movement backward, but also the state of car stop. This ambiguity must be solved by the car control system, which shall exclude from the movement a signal zone that is superior to the IVS threshold. Using the STL2D-HP sensor, 6 input / output signals are available (I/O), which are definable by the customer (for example actuating acoustic or light signals or devices like valves or engines, corresponding to particular output levels).

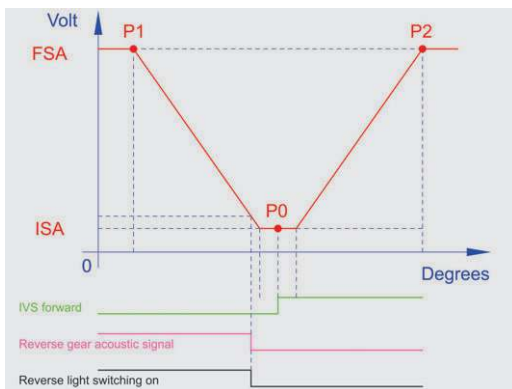

FORWARD / REVERSE GEAR WITH CENTRAL ZERO POSITION AND IMPLICIT VALIDATION

In the beside graphic a configuration example is represented that is studied to manage, through a lever, the movement forward / backward with central zero position. It is about an application example that is useful on vehicles that need a fast inversion of movement. In this version a single validation signal (forwards) is used to distinguish the two movement phases. Around the central point, the output signal remains at IS level, for a stretch corresponding to the achievement of a hysteresis threshold, which is implicitly defined. In this way, the vehicle will remain stopped assuring a safety zone around the resting point.