



COMBINED MECHANICAL CONTROLS FOR DIESEL MOTORSTOP, ENGAGED CLUTCH WITH PUMP CABLE INSIDE THE TUBE AND ORDER FORM MODEL CL 10D

Characteristics:

Control functioning: the levers are in dependent acting. The upper lever A is kept activated (lowered) if the lower lever B is in locking position

Application example: deadman device (engine switching off – lever A) combined with clutch lever control (lever B)

Upper lever A linear stroke in direct acting (mm): 16

Lower lever B linear stroke in locking position (mm): 17

Lever A material and colour: red nylon; holder in aluminium or in black nylon

Lever B material and treatment: zinc plated metal; holder in zinc plated metal

Assembly: on tubes

Assembly: on tubes

Lever A fastening type: with screw

Lever B fastening type: holder to be soldered, raw – metal hose clamp, right or left

Nib diameter for lever A (see note)

Tube outer diameter for lever B (mm): 22 - 26 - 27 - 28

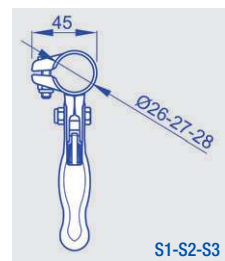
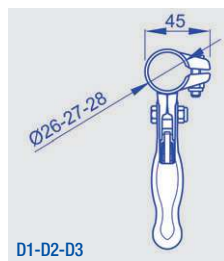
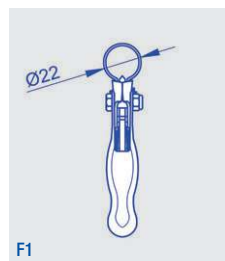
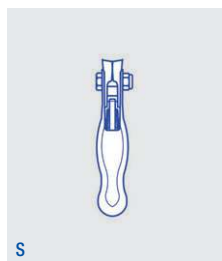
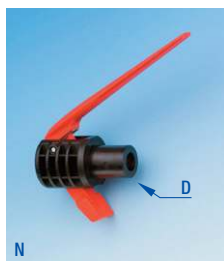
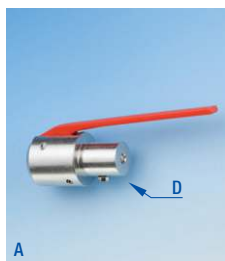
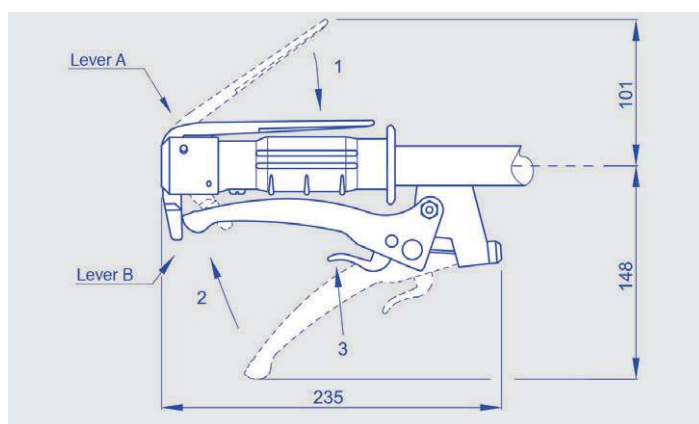

To order: compose, please, your product code inserting the boldfaced code corresponding to the chosen option in the proper square.

CL 10D

- Aluminium holder "A" with mm 18 "D" nib: **01**
- Aluminium holder "A" with mm 20 "D" nib : **02**
- Aluminium holder "A" with mm 21 "D" nib: **03**
- Aluminium holder "A" with mm 21,7 "D" nib: **04**
- Aluminium holder "A" with mm 22 "D" nib: **05**
- Aluminium holder "A" with mm 22,7 "D" nib: **06**
- Aluminium holder "A" with mm 25,8 "D" nib: **07**
- Aluminium holder "A" with mm 28 "D" nib: **08**
- Nylon holder "N" with mm 18 "D" nib: **09**
- Nylon holder "N" with mm 20 "D" nib: **10**
- Nylon holder "N" with mm 21 "D" nib: **11**
- Nylon holder "N" with mm 22 "D" nib: **12**
- Nylon holder "N" with mm 23 "D" nib: **13**

- Tube outer Ø mm 22: **14**
- Tube outer Ø mm 26: **15**
- Tube outer Ø mm 27: **16**
- Tube outer Ø mm 28: **17**

Holder to be soldered: **S**

- Metal hose clamp for outer tube Ø mm 22: **F1**
- Right metal hose clamp for outer tube Ø mm 26: **D1**
- Right metal hose clamp for outer tube Ø mm 27: **D2**
- Right metal hose clamp for outer tube Ø mm 28: **D3**
- Left metal hose clamp for outer tube Ø mm 26: **S1**
- Left metal hose clamp for outer tube Ø mm 27: **S2**
- Left metal hose clamp for outer tube Ø mm 28: **S3**

Note: Nib diameter for lever A: with holder in aluminium to be inserted inside the tube (mm): 18 - 20 - 21 - 21,7 - 22 - 22,7 - 25,8 - 28; with holder in nylon to be inserted inside the tube (mm): 18 - 20 - 21 - 22 - 23. **Knob:** shaped for assembly on tubes supplied in support of.



COMBINED MECHANICAL CONTROLS COMPATIBLE WITH UPPER LEVER CABLES MODEL CL 10D

Characteristics of compatible cables for lever "A":

Sheath diameter: Ø5 mm or Ø6 mm with inner antifriction tube

Sheath length: upon request

Wire diameter: Ø1,6 mm

Wire protrusion length: upon request

Sheath terminals: see table

Wire terminals: see table

Sheath options

Wire options

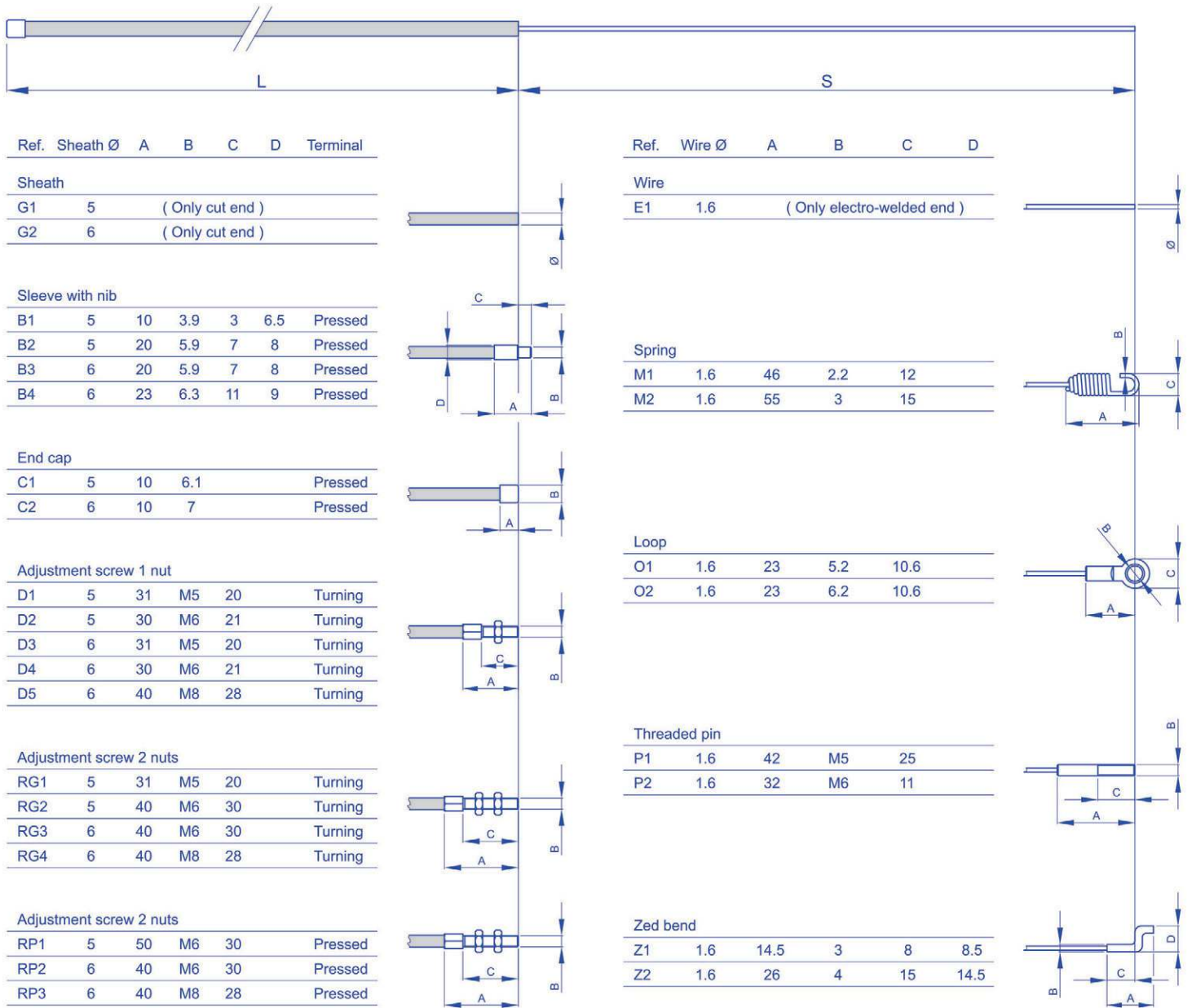

Ref.	Sheath Ø	A	B	C	D	Terminal
Sheath						
G1	5	(Only cut end)				
G2	6	(Only cut end)				

Sleeve with nib						
Ref.	Sheath Ø	A	B	C	D	Terminal
B1	5	10	3.9	3	6.5	Pressed
B2	5	20	5.9	7	8	Pressed
B3	6	20	5.9	7	8	Pressed
B4	6	23	6.3	11	9	Pressed

End cap						
Ref.	Sheath Ø	A	B	C	D	Terminal
C1	5	10	6.1			Pressed
C2	6	10	7			Pressed

Adjustment screw 1 nut						
Ref.	Sheath Ø	A	B	C	D	Terminal
D1	5	31	M5	20		Turning
D2	5	30	M6	21		Turning
D3	6	31	M5	20		Turning
D4	6	30	M6	21		Turning
D5	6	40	M8	28		Turning

Adjustment screw 2 nuts						
Ref.	Sheath Ø	A	B	C	D	Terminal
RG1	5	31	M5	20		Turning
RG2	5	40	M6	30		Turning
RG3	6	40	M6	30		Turning
RG4	6	40	M8	28		Turning

Adjustment screw 2 nuts						
Ref.	Sheath Ø	A	B	C	D	Terminal
RP1	5	50	M6	30		Pressed
RP2	6	40	M6	30		Pressed
RP3	6	40	M8	28		Pressed

Ref.	Wire Ø	A	B	C	D
Wire					
E1	1.6	(Only electro-welded end)			

Spring					
Ref.	Wire Ø	A	B	C	D
M1	1.6	46	2.2	12	
M2	1.6	55	3	15	

Loop					
Ref.	Wire Ø	A	B	C	D
O1	1.6	23	5.2	10.6	
O2	1.6	23	6.2	10.6	

Threaded pin					
Ref.	Wire Ø	A	B	C	D
P1	1.6	42	M5	25	
P2	1.6	32	M6	11	

Zed bend					
Ref.	Wire Ø	A	B	C	D
Z1	1.6	14.5	3	8	8.5
Z2	1.6	26	4	15	14.5



COMBINED MECHANICAL CONTROLS ORDER FORM FOR COMPATIBLE WITH UPPER LEVER CABLES MODEL CL 10D

To order:

The technical options that are represented on the opposite page are the standard personalizations which are provided from the company.

Among these possibilities, you can choose the cable construction that meets your requirements.

At first choose the sheath diameter and select the corresponding terminals among the possible options.

Find out your preferences and fill in the boxes with the number or the letters/number corresponding to your options.

Example: if you choose a sleeve with nib as terminal, indicate the code 05 or 06, according to your needs.

And so on for other variables.

The same procedure must be used to choose the wire: start choosing the terminals and then select the corresponding options.

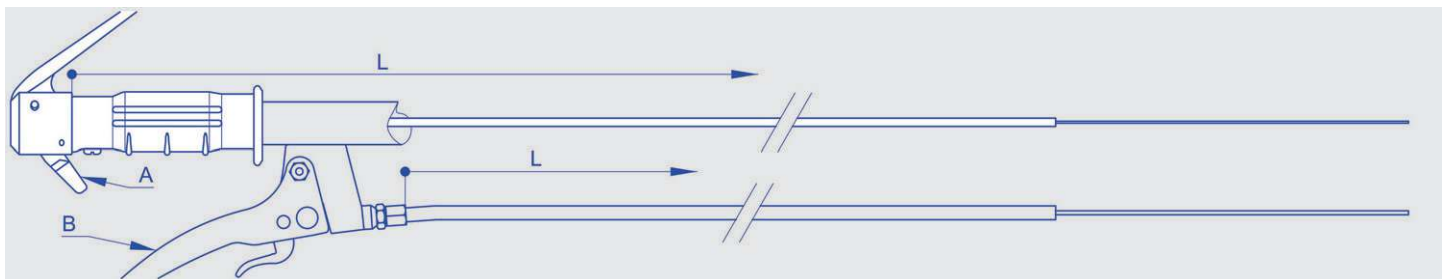

To order: compose, please, your product code inserting the boldfaced code corresponding to the chosen option in the proper square.

CL 10D - Lever A cable

<p>Sheath length (L) in mm: <input style="width: 100%; border: none; border-bottom: 1px solid black;" type="text"/></p> <p>Wire protrusion length (S) in mm: <input style="width: 100%; border: none; border-bottom: 1px solid black;" type="text"/></p> <p>Sheath Ø5 mm (only cut) G1: 01</p> <p>Sheath Ø6 mm (only cut) G2: 02</p> <p>Sleeve with nib B1: 03</p> <p>Sleeve with nib B2: 04</p> <p>Sleeve with nib B3: 05</p> <p>Sleeve with nib B4: 06</p> <p>End cap C1: 07</p> <p>End cap C2: 08</p> <p>Adjustment screw 1 nut D1: 09</p> <p>Adjustment screw 1 nut D2: 10</p> <p>Adjustment screw 1 nut D3: 11</p> <p>Adjustment screw 1 nut D4: 12</p> <p>Adjustment screw 1 nut D5: 13</p> <p>Turning adjustment screw 2 nuts RG1: 14</p> <p>Turning adjustment screw 2 nuts RG2: 15</p> <p>Turning adjustment screw 2 nuts RG3: 16</p> <p>Turning adjustment screw 2 nuts RG4: 17</p> <p>Pressed adjustment screw 2 nuts RP1: 18</p> <p>Pressed adjustment screw 2 nuts RP2: 19</p> <p>Pressed adjustment screw 2 nuts RP3: 20</p>	<p>Only electro-welded wire Ø1,6 mm without terminal E1: 21</p> <p>Spring M1: 22</p> <p>Spring M2: 23</p> <p>Loop O1: 24</p> <p>Loop O2: 25</p> <p>Threaded pin P1: 26</p> <p>Threaded pin P2: 27</p> <p>Zed bend Z1: 28</p> <p>Zed bend Z2: 29</p>
--	--

L = start point for sheath length. Other cables typologies are available upon request.



COMBINED MECHANICAL CONTROLS COMPATIBLE WITH LOWER LEVER CABLES MODEL CL 10D

Characteristics of compatible cables for lever "B":

- Sheath diameter: Ø6 mm or Ø7 mm with inner antifriction tube
- Sheath length: upon request
- Wire diameter: Ø1,9 mm or Ø2,5 mm
- Wire protrusion length: upon request
- Sheath terminals: see table
- Wire terminals: see table

Sheath options

Wire options

Ref.	Sheath Ø	A	B	C	D	Terminal
Sheath						
G1	6	(Only cut end)				
G2	7	(Only cut end)				
Sleeve with nib						
B1	6	20	5.9	7	8	Pressed
B2	6	23	6.3	11	9	Pressed
B3	7	17	5.8	6	10	Pressed
B4	7	23	6.3	11	9	Pressed
End cap						
C1	6	10	7			Pressed
C2	7	10.5	8			Pressed
Adjustment screw 1 nut						
D1	6	30	M6	21		Turning
D2	6	40	M8	28		Turning
D3	7	30	M6	21		Turning
D4	7	40	M8	28		Turning
Adjustment screw 2 nuts						
RG1	6	40	M6	30		Turning
RG2	6	40	M8	28		Turning
RG3	7	40	M6	30		Turning
RG4	7	40	M8	28		Turning
Adjustment screw 2 nuts						
RP1	6	40	M6	30		Pressed
RP2	6	40	M8	28		Pressed
RP3	7	40	M6	30		Pressed
RP4	7	40	M8	28		Pressed

Ref.	Wire Ø	A	B	C	D
Wire					
E1	1.9	(Only electro-welded end)			
E2	2.5	(Only electro-welded end)			
Fork					
F1	1.9	30	6	12	6
F2	1.9	38	6	24	6
F3	2.5	30	6	12	6
F4	2.5	38	6	24	6
F5	2.5	34	8	16	8
Spring					
M1	1.9	46	2.2	12	
M2	1.9	55	3	15	
M3	2.5	57	3.5	16	
Loop					
O1	1.9	23	5.2	10.6	
O2	1.9	23	6.2	10.6	
O3	1.9	31	6.2	12	
O4	1.9	32	8.3	16	
O5	1.9	32	10.2	16	
O6	2.5	31	6.2	12	
O7	2.5	32	8.3	16	
O8	2.5	32	10.2	16	
Threaded pin					
P1	1.9	44	M6	20	
P2	1.9	74	M6	46	
P3	2.5	44	M6	20	
P4	2.5	74	M6	46	
P5	2.5	49	M8	25	
Zed bend					
Z1	1.9	26	4	15	14.5



COMBINED MECHANICAL CONTROLS ORDER FORM FOR COMPATIBLE WITH LOWER LEVER CABLES MODEL CL 10D

To order:

The technical options that are represented on the opposite page are the standard personalizations which are provided from the company.

Among these possibilities, you can choose the cable construction that meets your requirements.

At first choose the sheath diameter and select the corresponding terminals among the possible options.

Find out your preferences and fill in the boxes with the number or the letters/number corresponding to your options.

Example: if you choose a Ø7 mm sheath and you want a sleeve with nib as terminal, indicate the code 05 or 06, according to your needs.

And so on for other variables.

The same procedure must be used to choose the wire: start choosing the diameter and then select the corresponding options.

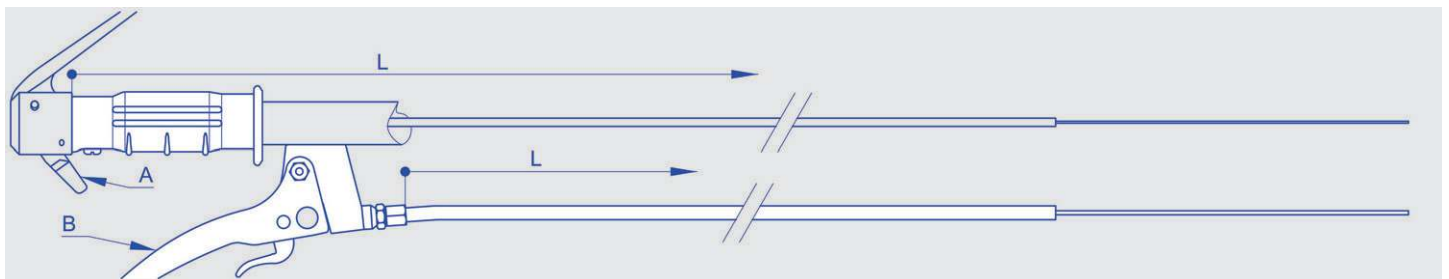

To order: compose, please, your product code inserting the boldfaced code corresponding to the chosen option in the proper square.

CL 10D - Lever B cable

<p>Sheath length (L) in mm: _____</p> <p>Wire protrusion length (S) in mm: _____</p> <p>Sheath Ø6 mm (only cut) G1: 01</p> <p>Sheath Ø7 mm (only cut) G2: 02</p> <p>Sleeve with nib B1: 03</p> <p>Sleeve with nib B2: 04</p> <p>Sleeve with nib B3: 05</p> <p>Sleeve with nib B4: 06</p> <p>End cap C1: 07</p> <p>End cap C2: 08</p> <p>Adjustment screw 1 nut D1: 09</p> <p>Adjustment screw 1 nut D2: 10</p> <p>Adjustment screw 1 nut D3: 11</p> <p>Adjustment screw 1 nut D4: 12</p> <p>Turning adjustment screw 2 nuts RG1: 13</p> <p>Turning adjustment screw 2 nuts RG2: 14</p> <p>Turning adjustment screw 2 nuts RG3: 15</p> <p>Turning adjustment screw 2 nuts RG4: 16</p> <p>Pressed adjustment screw 2 nuts RP1: 17</p> <p>Pressed adjustment screw 2 nuts RP2: 18</p> <p>Pressed adjustment screw 2 nuts RP3: 19</p> <p>Pressed adjustment screw 2 nuts RP4: 20</p>	<p>Only electro-welded wire Ø1,9 mm without terminal E1: 21</p> <p>Only electro-welded wire Ø2,5 mm without terminal E2: 22</p> <p>Fork F1: 23</p> <p>Fork F2: 24</p> <p>Fork F3: 25</p> <p>Fork F4: 26</p> <p>Fork F5: 27</p> <p>Spring M1: 28</p> <p>Spring M2: 29</p> <p>Spring M3: 30</p> <p>Loop O1: 31</p> <p>Loop O2: 32</p> <p>Loop O3: 33</p> <p>Loop O4: 34</p> <p>Loop O5: 35</p> <p>Loop O6: 36</p> <p>Loop O7: 37</p> <p>Loop O8: 38</p> <p>Threaded pin P1: 39</p> <p>Threaded pin P2: 40</p> <p>Threaded pin P3: 41</p> <p>Threaded pin P4: 42</p> <p>Threaded pin P5: 43</p> <p>Zed bend Z1: 44</p>
--	---