

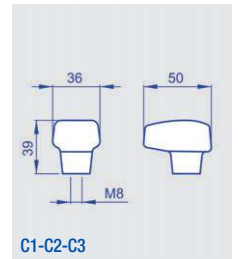

LATERAL MECHANICAL CONTROLS WITH TRACTION DIRECT ACTING (medium loads applications - single cable) AND ORDER FORM MODEL AG 30

Characteristics:

- Cable linear stroke: 72 mm
- Assembly: on walls Fastening type: with M6 through screws
- Functioning: frictioned having an adjustable stiffness Version: left or right
- Lever material: nylon with stainless steel insert Lever typology: straight or bent
- Lever length: 163 mm or 214 mm Knob material: nylon
- Knob typology: fixed (available only with stainless steel lever length 163 mm) or unscrewable
- Knob shape: round or rectangular Round knob colour: black Rectangular knob colour: black - red - orange

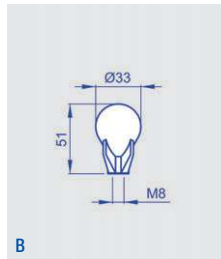
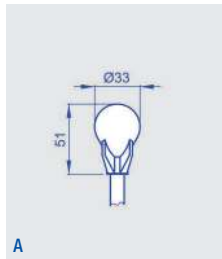
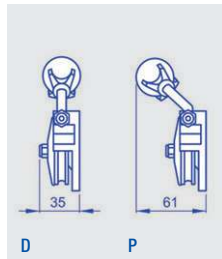
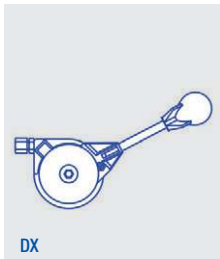
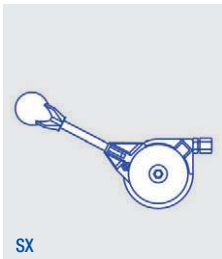
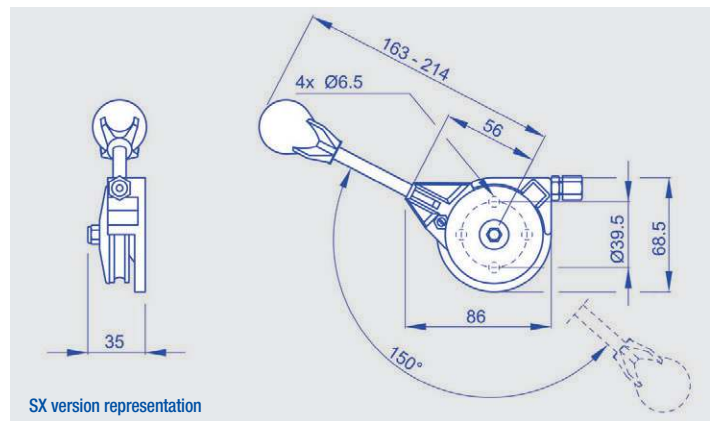

To order: compose, please, your product code inserting the boldfaced code corresponding to the chosen option in the proper square.

AG 30

Lever version left: **SX**
Lever version right: **DX**

Straight lever: **D**
Bent lever: **P**

Lever length 163 mm: **1**
Lever length 214 mm: **2**

Fixed round black knob (available only with lever 163 mm long): **A**
Unscrewable round black knob: **B**
Unscrewable rectangular black knob: **C1**
Unscrewable rectangular red knob: **C2**
Unscrewable rectangular orange knob: **C3**



LATERAL MECHANICAL CONTROLS COMPATIBLE CABLES MODELS AG 10 - AG 30 - AG 40T

Characteristics:

Sheath diameter: Ø6 mm or Ø7 mm with inner antifriction tube

Sheath length: upon request

Wire diameter: Ø1,9 mm or Ø2,5 mm

Wire protrusion length: upon request

Sheath terminals: see table

Wire terminals: see table

Sheath options

Wire options

Ref.	Sheath Ø	A	B	C	D	Terminal
Sheath						
G1	6	(Only cut end)				
G2	7	(Only cut end)				
Sleeve with nib						
B1	6	20	5.9	7	8	Pressed
B2	6	23	6.3	11	9	Pressed
B3	7	17	5.8	6	10	Pressed
B4	7	23	6.3	11	9	Pressed
End cap						
C1	6	10	7			Pressed
C2	7	10.5	8			Pressed
Adjustment screw 1 nut						
D1	6	30	M6	21		Turning
D2	6	40	M8	28		Turning
D3	7	30	M6	21		Turning
D4	7	40	M8	28		Turning
Adjustment screw 2 nuts						
RG1	6	40	M6	30		Turning
RG2	6	40	M8	28		Turning
RG3	7	40	M6	30		Turning
RG4	7	40	M8	28		Turning
Adjustment screw 2 nuts						
RP1	6	40	M6	30		Pressed
RP2	6	40	M8	28		Pressed
RP3	7	40	M6	30		Pressed
RP4	7	40	M8	28		Pressed

Ref.	Wire Ø	A	B	C	D
Wire					
E1	1.9	(Only electro-welded end)			
E2	2.5	(Only electro-welded end)			
Fork					
F1	1.9	30	6	12	6
F2	1.9	38	6	24	6
F3	2.5	30	6	12	6
F4	2.5	38	6	24	6
F5	2.5	34	8	16	8
Spring					
M1	1.9	46	2.2	12	
M2	1.9	55	3	15	
M3	2.5	57	3.5	16	
Loop					
O1	1.9	23	5.2	10.6	
O2	1.9	23	6.2	10.6	
O3	1.9	31	6.2	12	
O4	1.9	32	8.3	16	
O5	1.9	32	10.2	16	
O6	2.5	31	6.2	12	
O7	2.5	32	8.3	16	
O8	2.5	32	10.2	16	
Threaded pin					
P1	1.9	44	M6	20	
P2	1.9	74	M6	46	
P3	2.5	44	M6	20	
P4	2.5	74	M6	46	
P5	2.5	49	M8	25	
Zed bend					
Z1	1.9	26	4	15	14.5



LATERAL MECHANICAL CONTROLS ORDER FORM FOR COMPATIBLE CABLES MODELS AG 10 - AG 30 - AG 40T

To order:

The technical options that are represented on the opposite page are the standard personalizations which are provided from the company.

Among these possibilities, you can choose the cable construction that meets your requirements.

At first choose the sheath diameter and select the corresponding terminals among the possible options.

Find out your preferences and fill in the boxes with the number or the letters/number corresponding to your options.

Example: if you choose a Ø7 mm sheath and you want a sleeve with nib as terminal, indicate the code 05 or 06, according to your needs.

And so on for other variables.

The same procedure must be used to choose the wire: start choosing the diameter and then select the corresponding options.

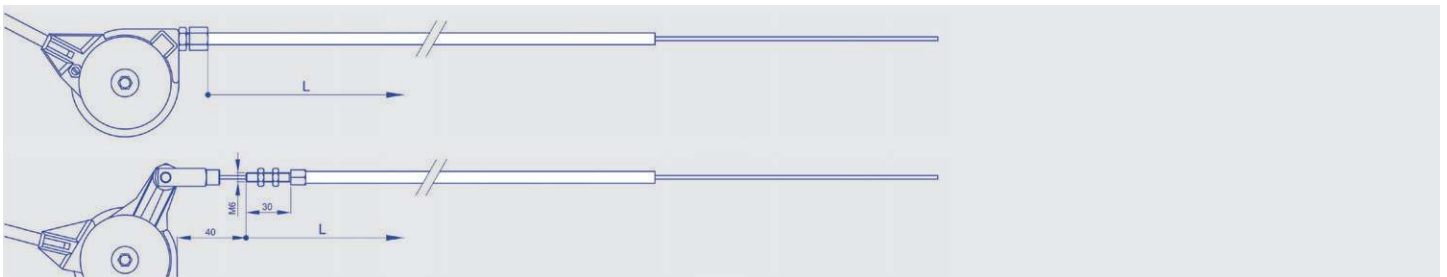

To order: compose, please, your product code inserting the boldfaced code corresponding to the chosen option in the proper square.

Cable					
-------	--	--	--	--	--

<p>Sheath length (L) in mm: _____</p> <p>Wire protrusion length (S) in mm: _____</p> <p>Sheath Ø6 mm (only cut) G1: 01</p> <p>Sheath Ø7 mm (only cut) G2: 02</p> <p>Sleeve with nib B1: 03</p> <p>Sleeve with nib B2: 04</p> <p>Sleeve with nib B3: 05</p> <p>Sleeve with nib B4: 06</p> <p>End cap C1: 07</p> <p>End cap C2: 08</p> <p>Adjustment screw 1 nut D1: 09</p> <p>Adjustment screw 1 nut D2: 10</p> <p>Adjustment screw 1 nut D3: 11</p> <p>Adjustment screw 1 nut D4: 12</p> <p>Turning adjustment screw 2 nuts RG1: 13</p> <p>Turning adjustment screw 2 nuts RG2: 14</p> <p>Turning adjustment screw 2 nuts RG3: 15</p> <p>Turning adjustment screw 2 nuts RG4: 16</p> <p>Pressed adjustment screw 2 nuts RP1: 17</p> <p>Pressed adjustment screw 2 nuts RP2: 18</p> <p>Pressed adjustment screw 2 nuts RP3: 19</p> <p>Pressed adjustment screw 2 nuts RP4: 20</p>	<p>Only electro-welded wire Ø1,9 mm without terminal E1: 21</p> <p>Only electro-welded wire Ø2,5 mm without terminal E2: 22</p> <p>Fork F1: 23</p> <p>Fork F2: 24</p> <p>Fork F3: 25</p> <p>Fork F4: 26</p> <p>Fork F5: 27</p> <p>Spring M1: 28</p> <p>Spring M2: 29</p> <p>Spring M3: 30</p> <p>Loop O1: 31</p> <p>Loop O2: 32</p> <p>Loop O3: 33</p> <p>Loop O4: 34</p> <p>Loop O5: 35</p> <p>Loop O6: 36</p> <p>Loop O7: 37</p> <p>Loop O8: 38</p> <p>Threaded pin P1: 39</p> <p>Threaded pin P2: 40</p> <p>Threaded pin P3: 41</p> <p>Threaded pin P4: 42</p> <p>Threaded pin P5: 43</p> <p>Zed bend Z1: 44</p>
--	---