

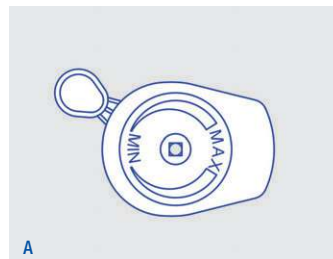

LATERAL MECHANICAL CONTROLS WITH TRACTION DIRECT ACTING (light loads applications – single cable) AND ORDER FORM **MODEL AE 250T**

Characteristics:

- Cable linear stroke: 39 mm or 46 mm
- Assembly: on tubes
- Fastening type: with through screw
- Tube outer diameter: 22 mm - 25 mm - 26 mm - 27 mm - 28 mm
- Functioning: frictioned or jerkily with 4 positioning marks
- Material: nylon Colour: black
- Writing on the cover: MIN-MAX or STOP-MIN-MAX-START

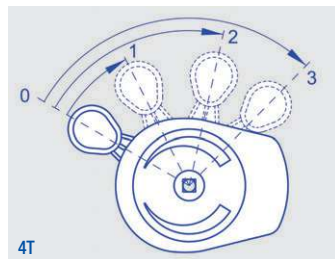
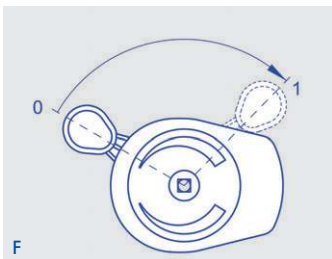
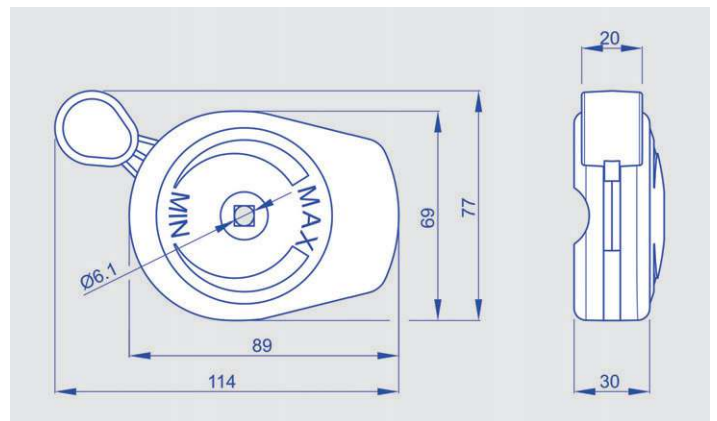

To order: compose, please, your product code inserting the boldfaced code corresponding to the chosen option in the proper square.

AE 250T

- Stroke mm 39: **1**
- Stroke mm 46: **2**

- Outer tube Ø mm 22: **3**
- Outer tube Ø mm 25: **4**
- Outer tube Ø mm 26: **5**
- Outer tube Ø mm 27: **6**
- Outer tube Ø mm 28: **7**

- Frictioned functioning: **F**
- Jerkily functioning with 4 positioning marks: **4T**

- Writing MIN-MAX: **A**
- Writing STOP-MIN-MAX-START: **B**



LATERAL MECHANICAL CONTROLS COMPATIBLE CABLES MODELS AG 20T - AE 250T - AE 300T

Characteristics:

Sheath diameter: Ø5 mm or Ø6 mm with inner antifriction tube

Sheath length: upon request

Wire diameter: Ø1,2 mm or Ø1,6 mm

Wire protrusion length: upon request

Sheath terminals: see table

Wire terminals: see table

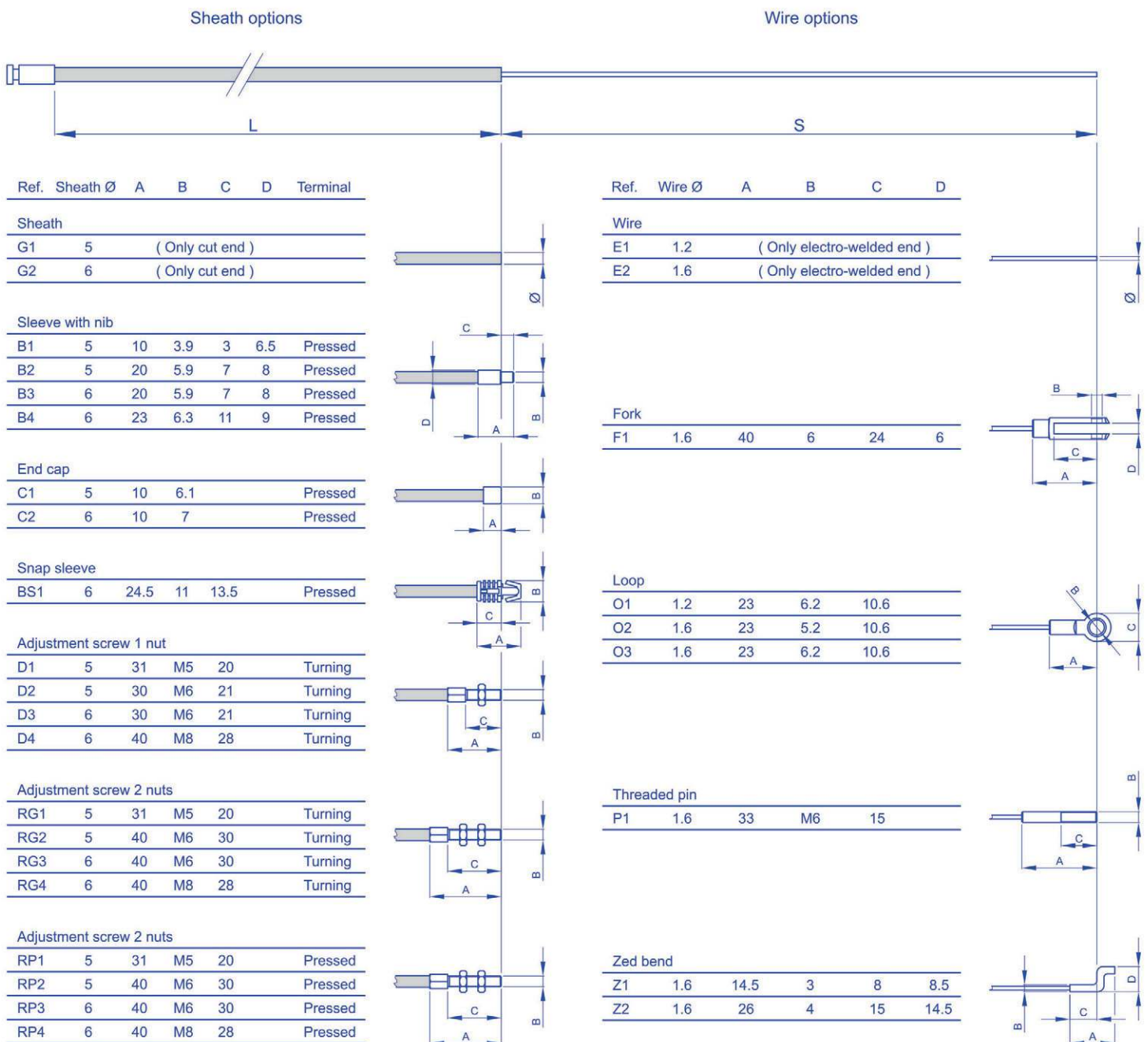



LATERAL MECHANICAL CONTROLS ORDER FORM FOR COMPATIBLE CABLES MODELS AG 20T - AE 250T - AE 300T

To order:

The technical options that are represented on the opposite page are the standard personalizations which are provided from the company.

Among these possibilities, you can choose the cable construction that meets your requirements.

At first choose the sheath diameter and select the corresponding terminals among the possible options.

Find out your preferences and fill in the boxes with the number or the letters/number corresponding to your options.

Example: if you choose a Ø6 mm sheath and you want a sleeve with nib as terminal, indicate the code 05 or 06, according to your needs.

And so on for other variables.

The same procedure must be used to choose the wire: start choosing the diameter and then select the corresponding options.

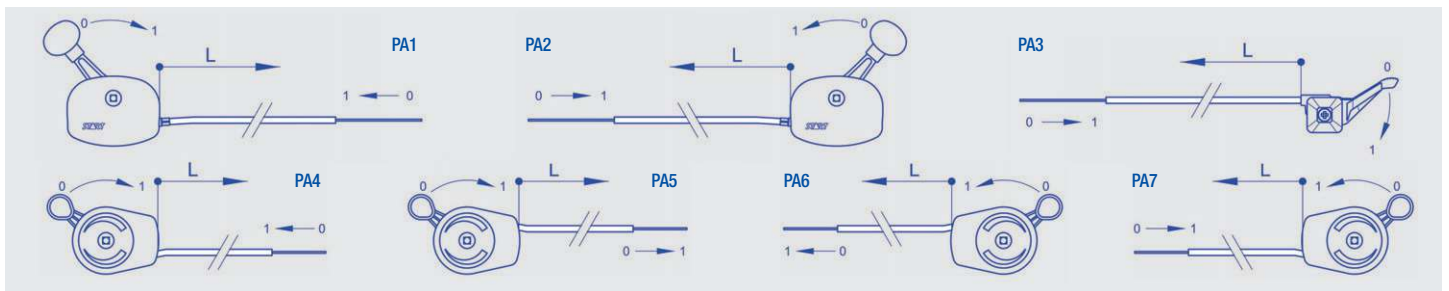

To order: compose, please, your product code inserting the boldfaced code corresponding to the chosen option in the proper square.

Cable					
--------------	--	--	--	--	--

Sheath length (L) in mm: _____
Wire protrusion length (S) in mm: _____

Sheath Ø5 mm (only cut) G1: **01**
Sheath Ø6 mm (only cut) G2: **02**

Sleeve with nib B1: **03**
Sleeve with nib B2: **04**
Sleeve with nib B3: **05**
Sleeve with nib B4: **06**

End cap C1: **07**
End cap C2: **08**

Snap sleeve BS1: **09**

Turning adjustment screw 1 nut D1: **10**
Turning adjustment screw 1 nut D2: **11**
Turning adjustment screw 1 nut D3: **12**
Turning adjustment screw 1 nut D4: **13**

Turning adjustment screw 2 nuts RG1: **14**
Turning adjustment screw 2 nuts RG2: **15**
Turning adjustment screw 2 nuts RG3: **16**
Turning adjustment screw 2 nuts RG4: **17**

Pressed adjustment screw 2 nuts RP1: **18**
Pressed adjustment screw 2 nuts RP2: **19**
Pressed adjustment screw 2 nuts RP3: **20**
Pressed adjustment screw 2 nuts RP4: **21**

Cable assembly: **PA1**
Cable assembly: **PA2**
Cable assembly: **PA3**
Cable assembly: **PA4**
Cable assembly: **PA5**
Cable assembly: **PA6**
Cable assembly: **PA7**

Only electro-welded wire Ø1,2 mm without terminal E1: **22**
Only electro-welded wire Ø1,6 mm without terminal E2: **23**

Fork F1: **24**

Loop O1: **25**
Loop O2: **26**
Loop O3: **27**

Threaded pin P1: **28**

Zed bend Z1: **29**
Zed bend Z2: **30**